

# 05 Series Connectors

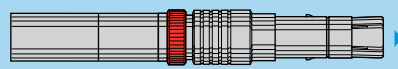

High voltage connectors of the new 05 miniature series have been specifically developed to meet the requirements of experimental nuclear research programme. The 05 series contains a miniature HV 12kV d.c. (test voltage) contacts. This crimp contact is removable from the shell and is inserted in a PEEK insulator. The actual mating is provided by the LEMO Push-Pull system, renowned for its reliability worldwide and a red safety nut to secure the connection. The compact design of these connectors makes them ideal for applications where minimal mass and space saving are critical factors.

## Interconnections



FFR Straight plug

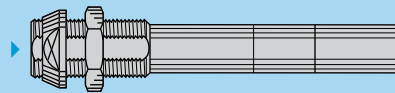

PES Fixed Socket

## LEMO's Push-Pull Self-Latching Connecting System

This self-latching system is renowned worldwide for its easy and quick mating and unmating features. It provides absolute security against vibration, shock or pull on the cable, and facilitates operation in a very limited space.

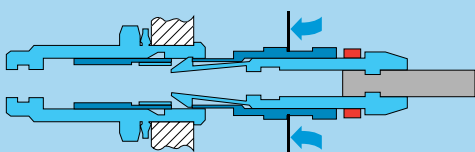
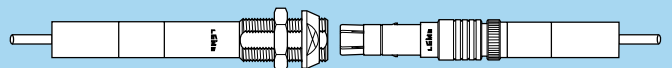
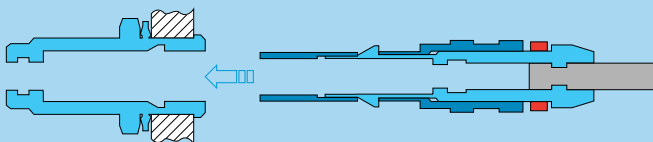

The LEMO self-latching system allows the connector to be mated by simply pushing the plug axially into the socket.

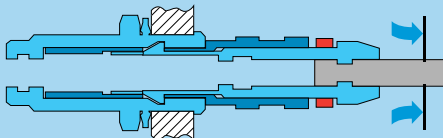

Once firmly latched, connection cannot be broken by pulling on the cable or any other component part other than the outer release sleeve.

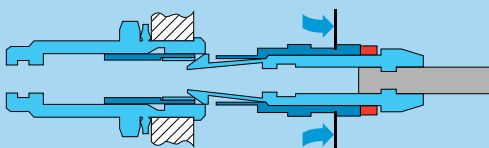

When required, the connector is disengaged by a single axial pull on the outer release sleeve. This first disengages the latches and then withdraws the plug from the socket.

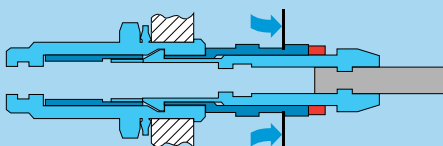

For added security a safety nut (shown in red) can prevent disengagement by blocking the motion of the outer release sleeve.

## Part Section Showing Internal Components

### Connector

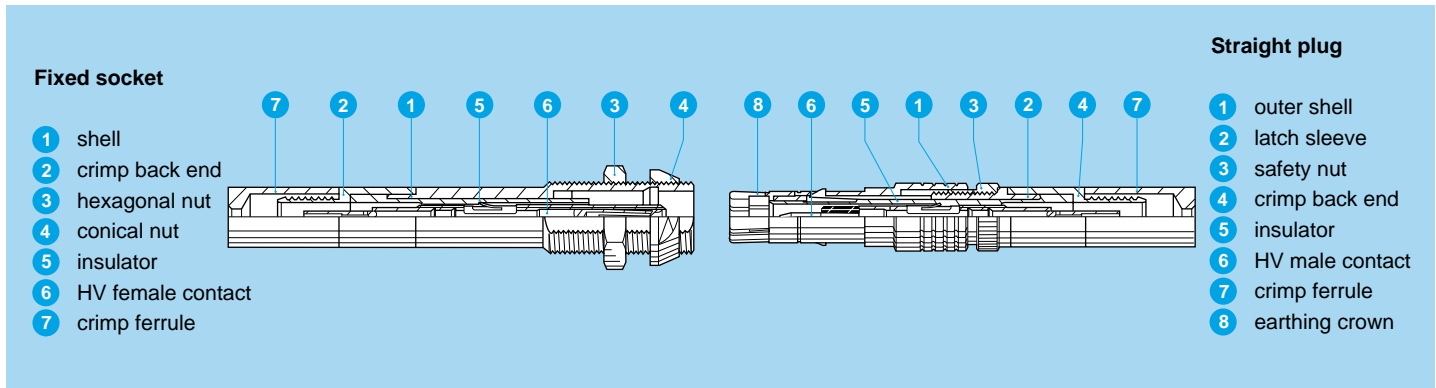

### HV Contact

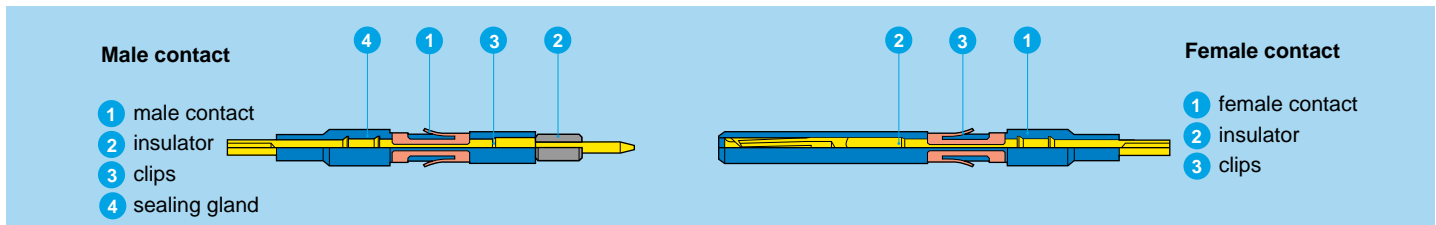

## Technical characteristics

### Mechanical and climatical

Characteristic	Value	Standard
Contact retention force	40 N	IEC 60512-8 test 15a
Working temperature	-20 °C to +125°C	
Mechanical life	> 200 cycles	IEC 60512-5 test 9a
Climatic class	20/125/21	IEC 60068-1
Radiation resistance	> 10 <sup>6</sup> Gy	

### Electrical characteristics

Characteristic	Value	Standard
Test voltage d.c. <sup>1)</sup>	12 kV (1 min.)	IEC 60512-2 test 4a
Rated current	4 A	IEC 60512-3 test 5a
Contact resistance	≤ 8 mΩ	IEC 60512-2 test 2a
Screen resistance	≤ 150 mΩ	IEC 60512-2 test 2f
Insulation resistance	≥ 10 <sup>12</sup> Ω	IEC 60512-2 test 3a

**Note:**

<sup>1)</sup> specific assembly instructions shall be respected. (see page 6 and 7)

### Materials and Treatment – Connector

Component	Material (standard)	Surface treatment (µm)
		Ni
Outershell + crimpend	Aluminium (AA 6012)	5
Safety nut	Aluminium (AA 6012)	Anodized red
Earthing crown	Aluminium special	5
Latch sleeve	Aluminium special	5
Hex and conical nut	Aluminium (AA 6012)	Anodized natural
Insulator	PEEK	–
Crimp ferrule	Aluminium (AA 6012)	5

### Contact

Component	Material (standard)	Surface treatment (µm)		
		Cu	Ni	Au
Male contact	Brass (UNS C38500)	0.5	3	1.0
Female contact	Bronze (UNS C54400)	0.5	3	1.5
Contact clips	Cu-Be (QQ-C-530)	–		
Insulator	PEEK	–		
Sealing gland	Silicone PVMQ	–		

## Models

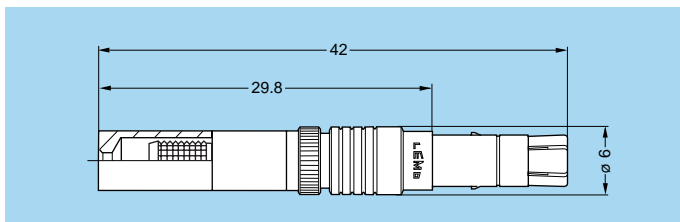
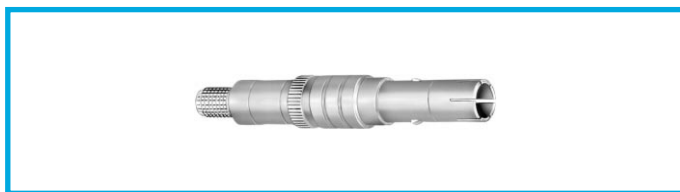

### FFR Straight plug for cable crimping, with safety nut

Part Number	Cable group
FFR.05.403.LLAE141	1
FFR.05.403.LLAE142	2

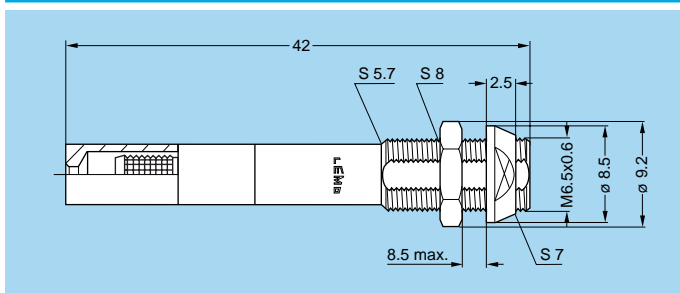
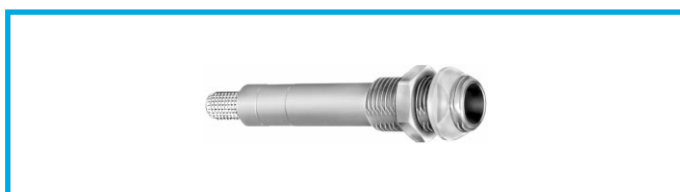

### PES Fixed socket, with two nuts, for cable crimping

Part Number	Cable group
PES.05.403.LLLE141	1
PES.05.403.LLLE142	2

## Recommended high voltage cables

Cable group	Manufacturer Part Number	CERN Type	Construction and dimensions								
			Conductor			Dielectric		Screen	Sheath		Corona screen
			Constr.	Mat.	∅	Mat.	∅	Mat.	Mat.	∅	
1	ABBNK - 45/94	HTC 50-1-1	7x0.17	CuSn	0.51	PE solid	1.5	CuSn 16x4x0.1	Polyolefine	3.3	yes
2	HABIA 31789-004-001	HFI 150 mini coax	Mono	Cu	0.16	HFI 150	0.5	Drain 2x0.1 + Alu polyester	HFI 150	1.15	no

## Accessories

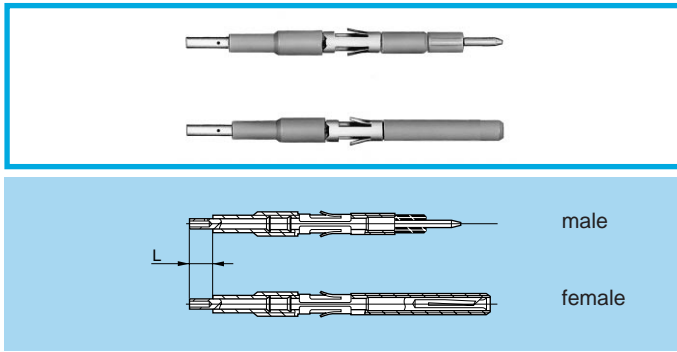

### FFA-ERA High Voltage Contacts

Contact Part Number		Cable group	L (mm)
Male contact	Female contact		
FFA.05.403.ZLA1	ERA.05.403.ZLL1	1	4
FFA.05.403.ZLA2	ERA.05.403.ZLL2	2	6

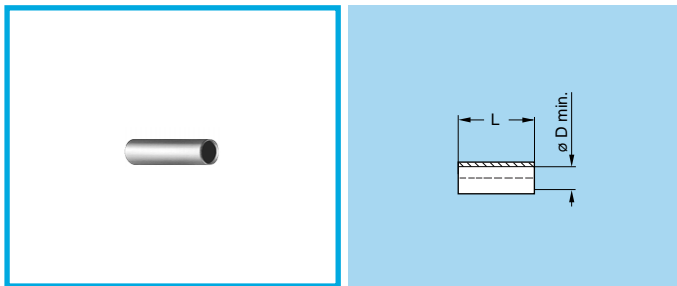

### GMA Heatshrink tube

Shall be ordered separately

Part number	Cable group	Supplier		øD (mm)	L (mm)
		Name	Product reference		
GMA.30.010.ST	1+2	RAYCHEM®	RNF 3000 3/1	3.0	13
GMA.15.010.ST	2	RAYCHEM®	RNF 3000 1.5/0.5	1.5	9

**Note:** for cable group 2, the two heatshrink tubes are necessary

- Material: Polyolefin transparent

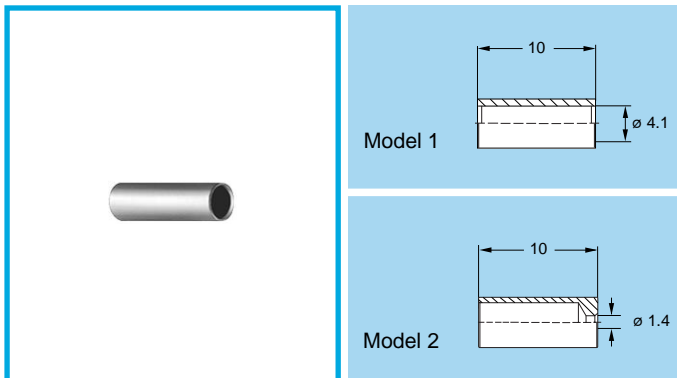

### FFS Crimp ferrule

Part number	Cable group	Model
FFS.05.160.PM	1	1
FFS.05.161.PM	2	2

- Material: Aluminium alloy (AA6012) nickel plated

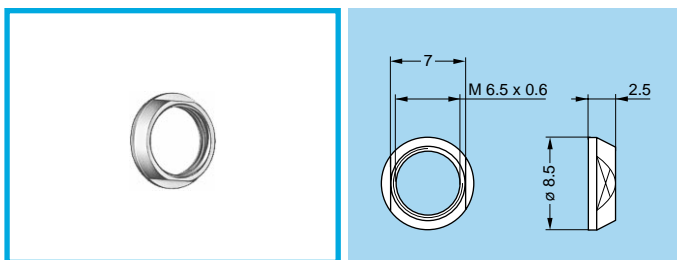

### GEC Conical nut

Part number
GEC.05.241.PT

- Material: Aluminium alloy (AA 6012) natural anodized.

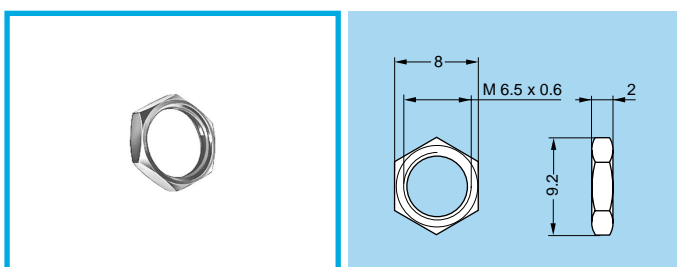

### GEA Hexagonal nuts

Part number
GEA.05.241.PT

- Material: Aluminium alloy (AA 6012) natural anodized.

## Tooling

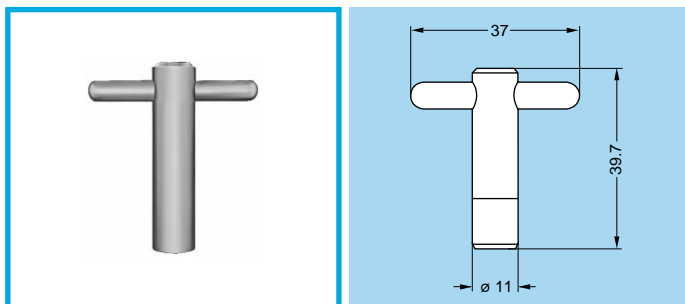

### DCH Spanner for conical nut

Part Number
DCH.91.113.9TN

- Material: Blackened steel.

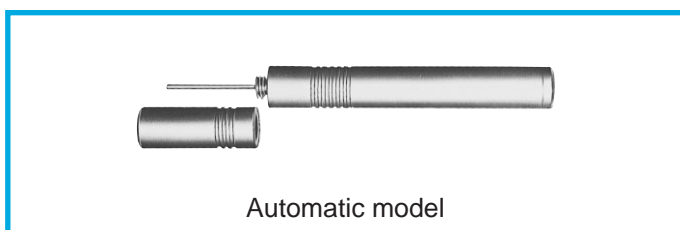

### DCF Extraction tools for HV contacts

Part Number
DCF.91.133.5LT



### DPH Crimping tool with die and positioner

Part Number	Applications	Cable group	Marking on die
DPH.99.005.2K	shield	1-2	DPH.91.005.2K
DPH.99.060.11K	centre contact	1	DPH.91.001.16K
DPH.99.065.11K	centre contact	2	DPK.91.001.16K



### DPN Dies and positioner

Part Number	Applications	Cable group	Marking on die
DPN.99.005.2K	shield	1-2	DPH.91.005.2K
DPN.99.060.11K	centre contact	1	DPH.91.001.16K
DPN.99.065.11K	centre contact	2	DPK.91.001.16K

- Dies material: Blackened steel

## Panel cut-out

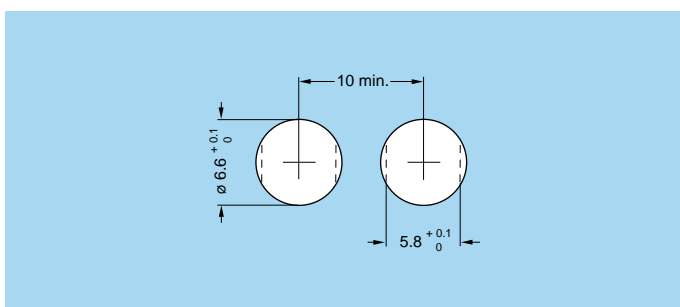

Recommended mounting nut torque: 0.8 Nm.

## Termination Instructions Cable Group 1

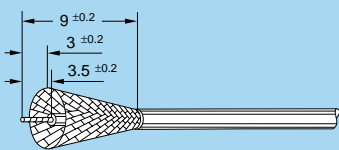
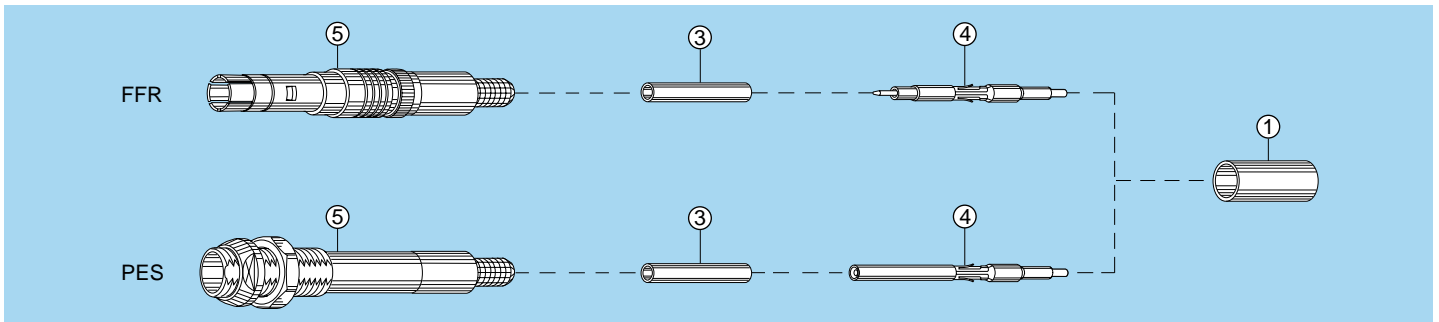

Dimensions in mm.

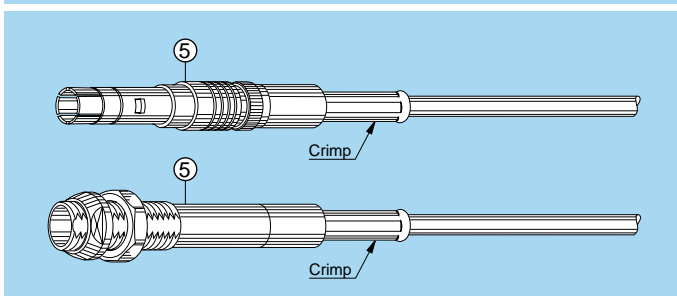
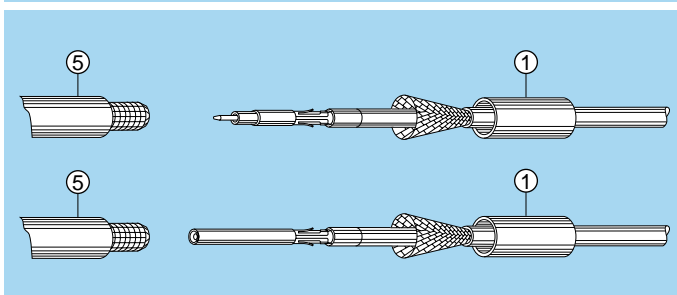
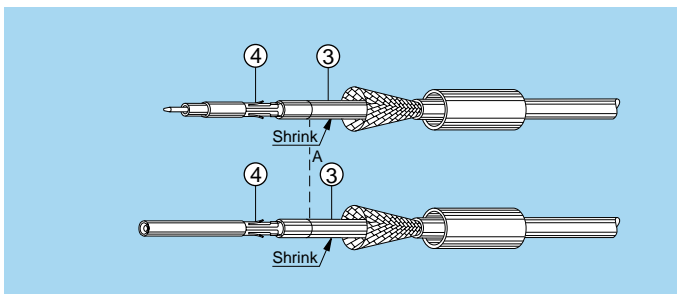
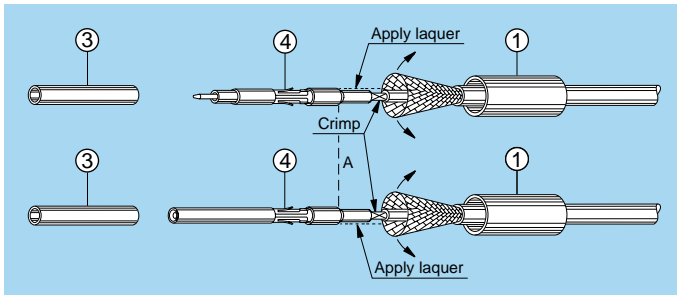

1. Strip the cable according to the given dimensions, remove carefully the cable corona screen, making sure that the cable dielectric is not damaged. Remove also the aluminium foil and the textile tape. Clean the dielectric with isopropyl alcohol.

2. Place the crimp ferrule ① on the cable. Widen completely the shield braid and fold it back over the jacket. Introduce the cable center conductor into the HV contact ④ until the contact end rests against the dielectric and the conductor is visible through the contact inspection hole. Crimp with the LEMO crimping tool DPH.99.060.11K. Cover the crimp section of the contact and the Peek end of the HV contact with a layer of insulating laquer. Let the laquer dry, approx. 15 min. Note: We recommend the laquer Urethan ref: Cellpack n° 912110

3. Slide the heatshrink tube ③ over the HV contact until it rests against the contact insulator. One end of the heatshrink tube shall be located at the position A of the HV contact insulator. Shrink the tube.

4. Fully introduce the HV contact into the connector shell ⑤. Check that the contact is correctly located and remains in position when given a gentle pull. Place the cable shield braid strand over the shell crimp back end, cut the length of braid in excess.

5. Slide the crimp ferrule over the cable shield until it rests against the connector shell. Crimp with the LEMO crimping tool DPH.99.005.2K.

## Termination Instructions Cable Group 2

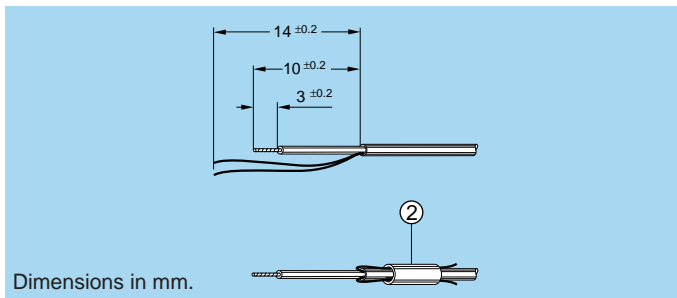
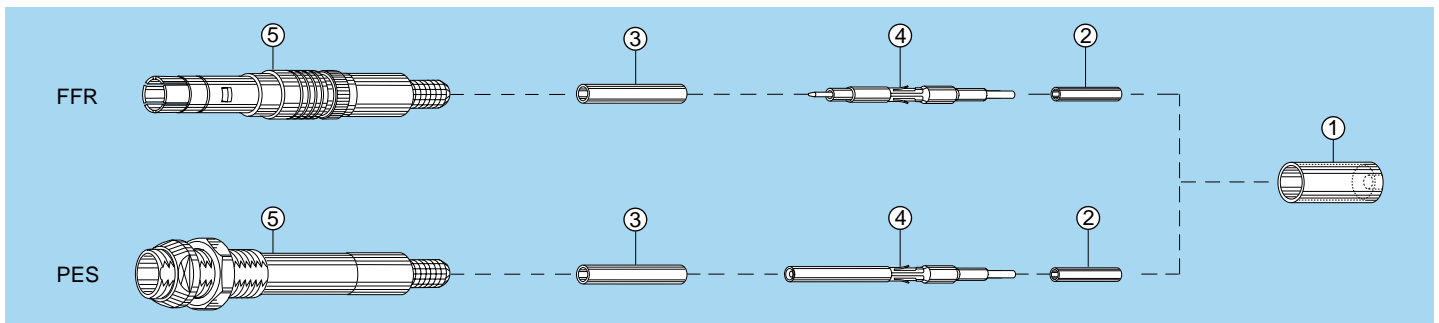

1. Strip the cable according to the given dimensions, cut the aluminium foil making sure that the dielectric is not damaged. Do not damage the 2 drain wires. Fold the drain wires back over the outer jacket and slide over the small heatshrink tube ②. Clean the dielectric with isopropyl alcohol.

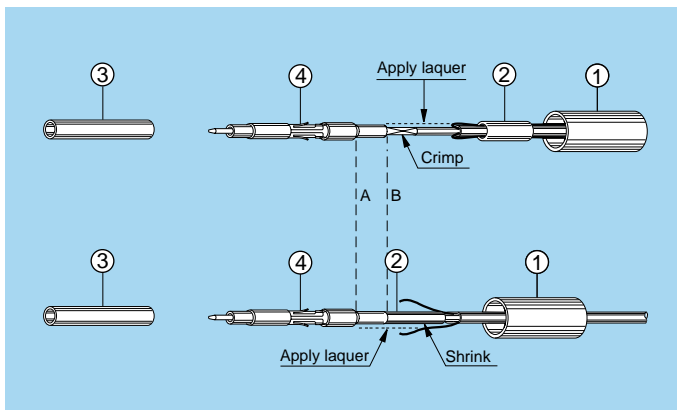

2. Place the crimp ferrule ① introducing first the small diameter on the cable. Introduce the cable center conductor and a part of the dielectric into the HV contact ④ until the conductor is fully visible through the contact inspection hole. Crimp with the LEMO crimping tool DPH.99.065.11K. Cover the crimp section of the contact and a short length of the dielectric with a layer of insulating laquer. Let the laquer dry, approx. 15 min. Note: We recommend the laquer Urethan ref: Cellpack n° 912110

Slide the heatshrink tube ② over the HV contact until it rests against the contact insulator at the position B. Shrink the tube. Cover the Peek end of the HV contact and the first heatshrink tube with a layer of the insulating laquer. Let the laquer dry, approx. 15 min.

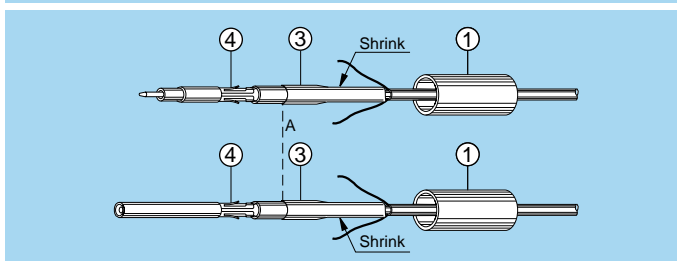

3. Slide the heatshrink tube ③ over the HV contact until it rests against the contact insulator. One end of the heatshrink tube shall be located at the position A of the HV contact insulator. Shrink the tube.

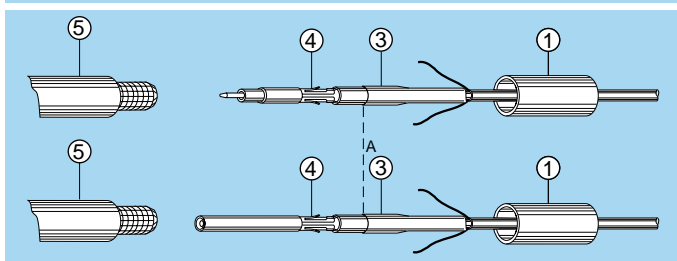

4. Fully introduce the HV contact into the connector shell ⑤. Check that the contact is correctly located and remains in position when given a gentle pull. Place the 2 drain wire around the shell crimp back end.

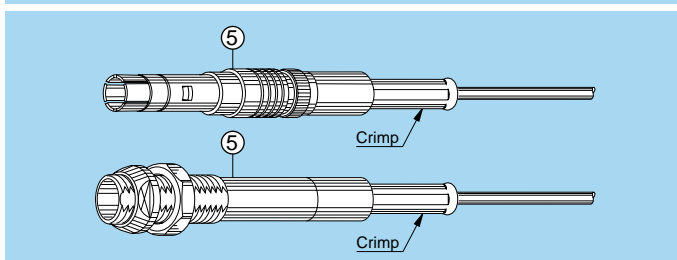

5. Slide the crimp ferrule over the cable shield until it rests against the connector shell. Crimp with the LEMO crimping tool DPH.99.005.2K.